

# Industrial Ethernet

## *Modular DIN-Rail Mounted Chassis for the Factory Floor*



### Ethernet for the Factory Floor

Ethernet is moving to the factory floor as the major network interface in many industrial and automation applications because it delivers higher speeds, better reliability and lower cost of ownership. Applications in this environment present special requirements that traditional enterprise Ethernet does not address. Metrobility's Industrial Ethernet DIN-rail chassis offers a modular, managed alternative to existing special-purpose technologies.

The RD20-24 is a two-slot, DIN rail chassis which will accommodate any of Metrobility's wide range of line cards for Ethernet, Fast Ethernet, 10/100 rate adaption, "redundant" line protection and restoration (LPR), and BWDM (single strand bi-directional wavelength division multiplexer). Because it is modular, users can choose the line card which best fits their needs:

- Ethernet, Fast Ethernet or Gigabit Ethernet interface line cards support both legacy and future applications
- Fast Ethernet or Gigabit Ethernet *access* line cards for extended management capabilities
- 10/100 rate adaption enables legacy 10Mbps devices to communicate with 100Mbps devices, protecting investments.
- Patented+ LPR line cards offer unique Network-on-Demand capabilities that allow for dynamic failover (6.72µsec over 100Mbps, one Ethernet packet) for loss of link or loss of traffic, or the ability to manually switch links for backup or maintenance operations.
- BWDM multiplexes receive and transmit signals over two separate wavelengths on a single strand of fiber, doubling the installed fiber capacity. This is an economical alternative to installing additional fiber to accommodate the growing network.
- A four-port switch card provides four 10/100 RJ-45 interfaces to enable up to three devices to share a single fiber connection.

Line cards are available with a variety of troubleshooting options including remote loopbacks, Link Loss Return, Link Loss Carry Forward, Auto-Recovery and Far End Fault. These features are model dependent, and are configurable manually through a DIP switch on each device, or through Metrobility's NetBeacon® Element Manager or WebBeacon™ software.

### Management Options

Metrobility's NetBeacon management software offers an SNMP-based element management system that supports functional, operational and environmental monitoring and management of Metrobility's mixed-media physical layer network elements from a central management station.

Using NetBeacon, network managers can access each device remotely, adjust operating parameters quickly across the network. All platform configuration updates, maintenance, and diagnostics can be performed remotely.

Extensive real-time information on SNMP MIB-II and Metrobility-specific MIB statistics – plus alarm thresholds and notification procedures – enable early problem identification, fast fault isolation and proactive management to prevent problems before they affect operations.

WebBeacon, a web kernel embedded in the management card operating system, enables web-based management via a browser.

\* using Metrobility's Access Line Card

+U.S. Patent No. 6,058,479

- *Modular design supports mix and matching of connection types and speeds*
- *Management option for easy troubleshooting and configuration*
- *High availability option with dual links*
- *Redundant power inputs*
- *Rugged DIN-rail mounted enclosure*

### The Metrobility® Difference

- Modular two-slot chassis
- SNMP and web-based management option
- Copper to singlemode or multimode fiber
- Multimode fiber to singlemode fiber
- SC, ST or LC connectors
- Distances up to 100km over SM
- Line Protection and Restoration for high availability
- Troubleshooting features
  - Remote Loopback
  - Link Loss Carry Forward
  - Link Loss Return
  - Auto-Recovery
  - Far End Fault

### Product Highlights

- Meets DIN 46 277 and DIN EN 50 022 physical standards
- Operating temperatures
  - Chassis: -20° C to 70° C
  - Line Cards: 0° C to 50° C
  - 20° C to 70° C (R643 and R133 only)
- Dual power input with screw-down terminal block supports 24Vdc.
- Industrial enclosure of 20 gauge cold rolled steel (CRS), bright zinc chromate finish.
- Convection cooling. No rotating mechanical parts, i.e. fans.

# Applications

Metrobility's DIN-rail chassis and media conversion line cards provide reliable copper-to-fiber connectivity for industrial applications which may be migrating to Ethernet. These include:

- |                                  |                         |
|----------------------------------|-------------------------|
| Factory Automation               | Test and Measurement    |
| Interconnection of Ethernet PLCs | Process Control         |
| Ethernet I/O                     | Remote Data Acquisition |
| Machine Monitoring               | Communications Gateway  |
| Environmental Control            |                         |

## Example 1 - Basic copper-to-fiber connectivity from control room to factory floor

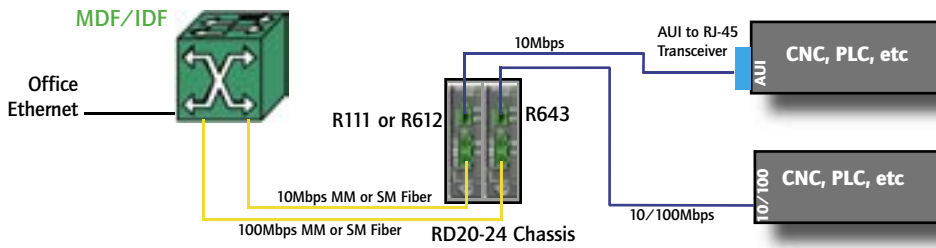

## Example 2 - Line Protection and Restoration

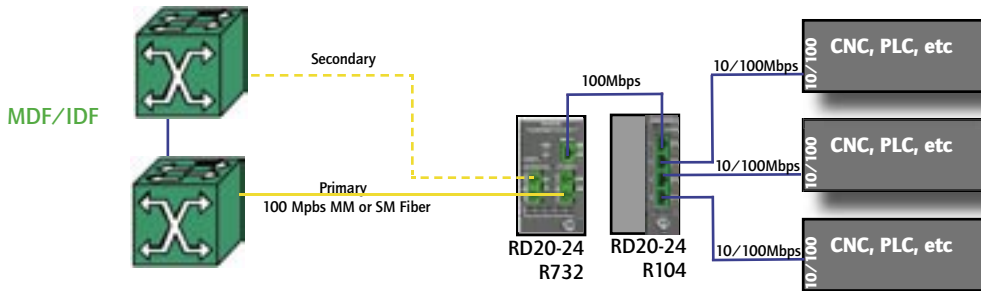

## Example 3 - Linking multiple devices through a four-port switch

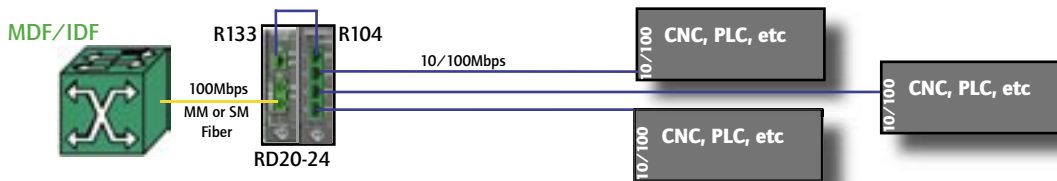

## Example 4 - Managed remote links

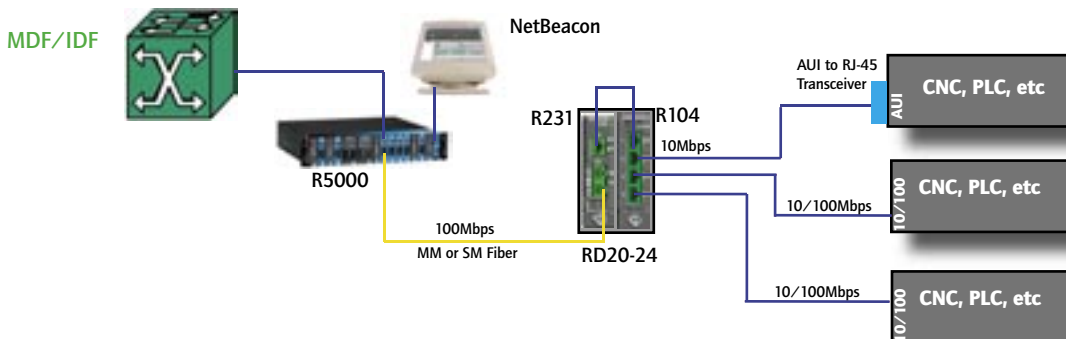



Access Line Cards (shown in blue) and Interface Line Cards may be mixed within any Metroblity chassis.

The management card collects a wide variety of information about each interface line card including name, type, speed, and link status. Diagnostics such as Link Loss Carry Forward, Link Loss Return, Auto-Recovery and Far End Fault can also be set for each interface line card and options are dependent on the type of line card, e.g. redundant, 10/100, etc. (see below). A wide range of alarms are also available to notify network administrators of any changes in link status, configurations, resets, switchovers, power supply conditions and temperature.

## NetBeacon configuration screens for interface line cards

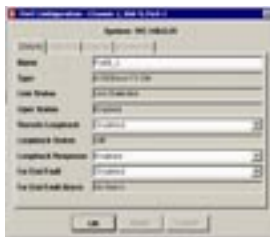

Fiber Port Configuration for 100Mbps Interface Line Card (R133-14)

- Name
- Type
- Description
- Oper Status
- Remote Loopback
- Loopback Status
- Loopback Response
- Far End Fault
- Far End Fault Alarm

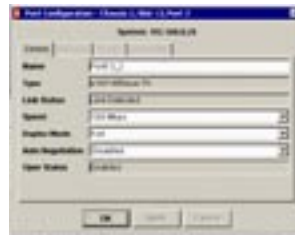

Fiber Port Configuration for 10/100Mbps Interface Line Card (R643-14)

- Name
- Type
- Link Status
- Speed
- Duplex Mode
- Auto Negotiation
- Oper Status

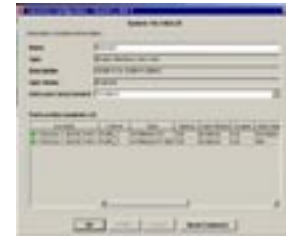

Converter Configuration for 100Mbps Interface Line Card (R133-14)

- Name
- Type
- Description
- Oper Status
- Link Loss Carry Forward

## Access Line Cards for Remote Site Management

Access line cards offer the same features as the interface line card *plus* advanced **remote site** management features which are not available in interface line cards. These features include line card voltage and temperature (Quality of Equipment), RMON statistics (Quality of Line), optical power measurement (Quality of Optical Amplitude), remote loop back, and bandwidth provisioning to enable proactive network management and reduce operating expenses.

Access line cards can be managed from a central management station without a management card at the remote site. They require no IP address or SNMP agent.

## NetBeacon management options for access line cards



Quality of Optical Amplitude (integral optical power meter) and Remote Loopback



Quality of Equipment (Card input and output voltage, external power and temperature)



Quality of Line (RMON Statistics)



Data may be tracked and stored up to 28 days when used in conjunction with the R502-M management card and NetBeacon's database option.

### Interface Line Card Options:

- 10BASE-T to 10BASE-FL (SM or MM)
- 10BASE-T to 10BASE-2 (BNC)
- 10/100BASE-TX to 10BASE-FL (MM)
- 10/100BASE-TX to 100BASE-FX (SM or MM)
- 100BASE-TX to 100BASE-FX (SM or MM)
- 100BASE-TX to 100BASE-FX BWDM (SM)
- 100BASE-FX (SM or MM) to 100BASE-FX (SM or MM)
- 100BASE-TX to (2) 100BASE-FX (SM or MM)
- 1000BASE-T to 1000BASE-X (SM or MM)
- 1000BASE-X (SM or MM) to 1000BASE-X (SM or MM)
- 1000BASE-T to (2) 1000BASE-X (SM or MM)

### Access Line Card Options:

- 100BASE-TX to 100BASE-FX (SM or MM)
- 1000BASE-T to 1000BASE-X (SM or MM)\*

\* available November, 2003

### Switching Line Card Options:

- 4-Port 10/100BASE-TX Switch

### MicroTransceivers:

- 10BASE-T to AUI
- 10BASE-T to 10BASE-2 (BNC)
- 10BASE-FL to AUI (SM or MM)

For additional information on all line cards, including part numbers and specifications, please refer to the individual datasheet or user manual.

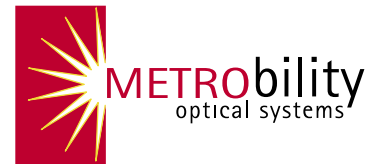

Metrobility Optical Systems, Inc.  
25 Manchester Street  
Merrimack, NH USA 03054  
phone 1.603.880.1833  
fax 1.603.594.2887  
www.metrobility.com

**Metrobility Optical Systems is an innovative next generation optical networking company whose focus is on delivering optical access platforms and to harness the power of Ethernet and fiber optics to deliver superior network edge access, connectivity, and wavelength multiplexing solutions.**

### Features Matrix:

Product Family	Speed (Mbps)	Auto CrossOver	Auto FD/HD	Auto 10/100/1000	LLCF	LLR	Auto Recovery	Far End Fault	Remote Loopback	Quality of Line	Quality of Equip	Optical Power Measurement	RMON Statistics	BWDM	Redundant Links	Operating Temp
R111	10	x			x											0°C - 50°C
R612	10	x	x	x	x	x										0°C - 50°C
R133	100	x	x		x			♦	x					x		-20°C - 70°C
R643	10/100	x	x	x	x	x	x		x					x		-20°C - 70°C
R231	100	x	x		x	x		♦	♦	♦	♦	♦	♦	x		0°C - 50°C
R711	10	x													x	0°C - 50°C
R732	100	x													x	0°C - 50°C
R752	1000	x	x		x										x	0°C - 50°C
R152	1000	x			x	x			x					x		0°C - 50°C
R851	10/100/1000	x	x	x	x	x		♦	x	♦	♦	♦	♦			0°C - 50°C

Features marked ♦ require NetBeacon or WebBeacon

### Model Description

RD20-24 2-slot, DIN-rail chassis

### Management Options

R5000 17-slot IDF/MDF chassis

R502-M Management Card

R104-11 4-port switch

NetBeacon NetBeacon Element Manager

For additional information on the R5000 chassis, management card and NetBeacon, including part numbers and specifications, please refer to the respective datasheet or user manual.

### RD20-24 Chassis Specifications

#### Physical Dimensions

RD20-24 3.0"W x 5.1"H x 5.1"D  
7.62cm x 13.0cm x 13.0cm

#### Power Inputs

Dual 24Vdc @ .75A  
10 to 30Vdc range

#### Environmental

Operating Temperature -20°C to 70°C  
Operating Humidity 5% to 95%  
Storage Temperature -30°C to 70°C

#### Regulatory

Compliance IEEE 802.3/IEEE 802.3u  
DIN 46 277, DIN EN 50 022  
DIN 43 880  
Safety and EMC FCC, UL, CE, CSA



Metrobility Optical Systems, Inc.

The information in this publication is accurate as of its publication date; such information is subject to change without notice. Metrobility Optical Systems is not responsible for any inadvertent errors. Metrobility, Metrobility Optical Systems, Lancast, AutoTwister, MicroChassis, "twister," and NetBeacon are registered trademarks, and "redundant twister" and WebBeacon are trademarks of Metrobility Optical Systems. All other trademarks are the property of their respective owners.

Copyright 2003 Revised February 2004  
Metrobility Optical Systems, Inc.

Printed in U.S.A.